

IzyCHAIR



Find this notice
at www.logo-silver.fr

ULTRA-LIGHT AND COMPACT,
CONVENIENT AND EASY ASSEMBLY AND DISASSEMBLY FOR TRAVEL.

LOGO  SILVER
by **AMYLOR**

CONTENTS

I. INTRODUCTION.....	4
II. SAFETY.....	5
2.1 EXPIRATION DATE.....	5
2.2 INSTRUCTIONS BEFORE USE.....	5
2.3 ATTENTION DURING USE.....	5
2.4 ELECTROMAGNETIC INTERFERENCE.....	6
III. STRUCTURE AND PERFORMANCE.....	7
3.1 STRUCTURE OF THE IZYCHAIR.....	7
3.2 ELECTRIC DIAGRAM OF N5519.....	8
3.3 PRODUCT SOFTWARE VERSION.....	8
IV. SPECIFICATION.....	9
V. INSTALLATION, FOLDING AND ADJUSTMENT.....	10
5.1 INSTALLATION.....	10
5.2 FOLDING AND STORAGE.....	10
5.3 ADJUSTMENT.....	11
VI. USE AND OPERATION.....	12
6.1 USE.....	12
6.1.1 CONTROLLER.....	12
6.1.2 BATTERY USAGE.....	13
6.1.3 CHARGING THE BATTTERIES.....	13
6.1.4 OVERCHARGE.....	14
6.1.5 BRAKE LEVER.....	14
6.1.6 SAFETY BELT.....	14
6.2 OPERATION.....	14
6.2.1 PREPARATION BEFORE OPERATION.....	14
6.2.2 PRACTICE BEFORE OPERATION.....	15
VII. FAULT DIAGNOSIS AND TROUBLESHOOTING.....	16

VIII. SAFETY DEVICES AND ACCIDENT MANAGEMENT	17
IX. MAINTENANCE.....	17
9.1 MOISTURE.....	17
9.2 TEMPERATURE.....	17
9.3 GENERAL GUIDELINES	17
9.4 MAINTENANCE AFTER USE.....	18
9.5 DAILY CHECKS	19
9.6 CLEANING	19
X. REPAIR.....	19
XI. STORAGE	20
XII. OPENING AND VERIFICATION	20
XIII.WARRANTY.....	21
13.1 FIVE-YEAR WARRANTY	21
13.2 COVERED BY WARRANTY.....	21
13.3 NOT COVERED BY WARRANTY	21

I. INTRODUCTION

Read and follow all instructions, warnings, and notes in this manual before attempting to operate your power wheelchair for the first time. If there is any information in this manual which you do not understand, or if you require additional assistance for assembly or operation, please contact your authorized local provider.

The symbols below in this manual are used to identify warnings and important information. They are all very important to your safety. It is strongly recommended that you read and understand them completely.



WARNING!

Failure to heed the warnings in the manual may result in personal injury.



CAUTION!

Failure to heed the cautions in the manual may result in damages to the IZYCHAIR.

This IZYCHAIR integrates advanced technology with modern style. Notably, its structure for quick disassembly and assembly are very convenient for you to store or place in the trunk of your vehicle while traveling. We are certain that the design features, excellent performance and trouble-free operation of this product will ensure that your daily life is more convenient.

This IZYCHAIR is suitable for all disabled persons, the elderly and the infirm who have difficulty walking. The maximum user weight is 100kg.

This is an indoor type power wheelchair, Model N5519. Here, “N” indicates an indoor IZYCHAIR, “5” is the category code of products, “216” is the serial number of this model.

This is an indoor type power wheelchair, and is suitable for indoor use and on flat pathways around buildings, but not for on grass, gravel, or larger slopes and motorways, or for rainy and snowy conditions.

II. SAFETY USE

2.1 EXPIRATION DATE

This IZYCHAIR is an anti-bacterial, reusable product without chemical substances. The chair safety and validity period for clinical use not only depends on the structural strength of the products, but also on the user operation and environment, user habits, whether they are in accordance with periodic maintenance, and other additional factors.

Our products are valid for 7 years from the date of production.

2.2 INSTRUCTIONS BEFORE USE

- The user must fully read and understand this manual.
- The maximum weight capacity is 100kg, please do not overload the chair. Only one person at a time can drive, please do not carry passengers.
- Please do not drive when tired or after drinking alcohol.
- Do not drive at night or in the case of poor visibility.
- Please perform a self assessment before driving and refer to the manual section 5.3 'Commissioning' and 6.2.1 'Practice before operation' if driving for the first time.
- This chair is not waterproof, do not expose it to rain or snow and do not attempt to drive it in rain or snow.

2.3 ATTENTION DURING USE

- This IZYCHAIR can be driven on a smooth flat surface, but not on muddy, uneven, soft, narrow, icy or dangerous roads without guardrails or pathways.
- This IZYCHAIR has a limited obstacle clearing capacity, when you arrive at an obstacle you should reduce the speed and proceed slowly.
- This IZYCHAIR has a limited climbing ability, the climbing angle is $\geq 3^\circ$.
- Please avoid driving in crowds and traffic.
- Please make sure that the control system is securely installed. The joystick position is upright and correct. Make sure that your safety belt is fastened. Tilt back as far as possible, and lean against the backrest in case of sudden involuntary jolts while driving.
- Press the on/off button, and check firstly if the current maximum speed setting is appropriate for your own operating proficiency, if not, it should be adjusted for safety; We recommend that you drive slowly at the beginning of every use, and then gradually accelerate.

**WARNING!**

If your wheelchair moves involuntarily, release the joystick immediately and the wheelchair will stop automatically. If the joystick malfunctions and the brake fails, please cut off the power.

**CAUTION!**

Please pull the lever upwards when the power chair comes to an incline, or it will roll downward at low speed, resulting in personal injury.

2.4 ELECTROMAGNETIC INTERFERENCE

Your wheelchair may be traveling through areas affected by electromagnetic interference from some transmitters such as radio, wireless intercom, mobile phones and radars etc. In these cases, your wheelchair's driving ability may be affected. Electromagnetic interference may affect the control system of the electric wheelchair. Some disturbances may cause brake failure, involuntary starts or movements, and may cause permanent damage to the control system.

Electromagnetic Interference Classification

- Short-band radio transceiver: These radios have antennas, such as radio waves in urban bands, walkie-talkies, mobile network systems and signal transmission devices.
- Medium-band mobile radio transceiver: These are usually installed in a building or outside in the antenna of a vehicle. For example: police, fire brigade, taxi, ambulance and other radio transceivers.
- Large band radio transceiver: These are usually installed in the antenna of a tower, such as: commercial, radio or TV transmission systems.

**WARNING!**

The Wheelchair and battery chargers meet the following standard code: GB / T 18029.21 Wheelchair - Part 21: Requirements and test methods for electromagnetic compatibility of the electric scooters and battery chargers.

**WARNING!**

The chair may be affected by Electro-Magnetic Interference (EMI) while driving. Such interference may be from mobile phones, EAS systems, etc.

Prevention of Electromagnetic Interference

- Do not use hand-held radio transceivers such as mobile phones, radios, etc; when the wheelchair power is turned on.
- Avoid nearby radio transmission systems, such as radio stations, television stations.
- If the power wheelchair is defective or the brakes fail, please contact your company or dealer.

III. STRUCTURE AND PERFORMANCE

3.1 STRUCTURE OF THE IZYCHAIR

This IZYCHAIR consists of the main parts including the front wheels, drive wheels, frame, controller; motor; armrest, push handle, backrest, seat base, footrest, battery case and charger, the structure shown in Figure 1.



fig. 1

3.2 ELECTRIC DIAGRAM OF N5519

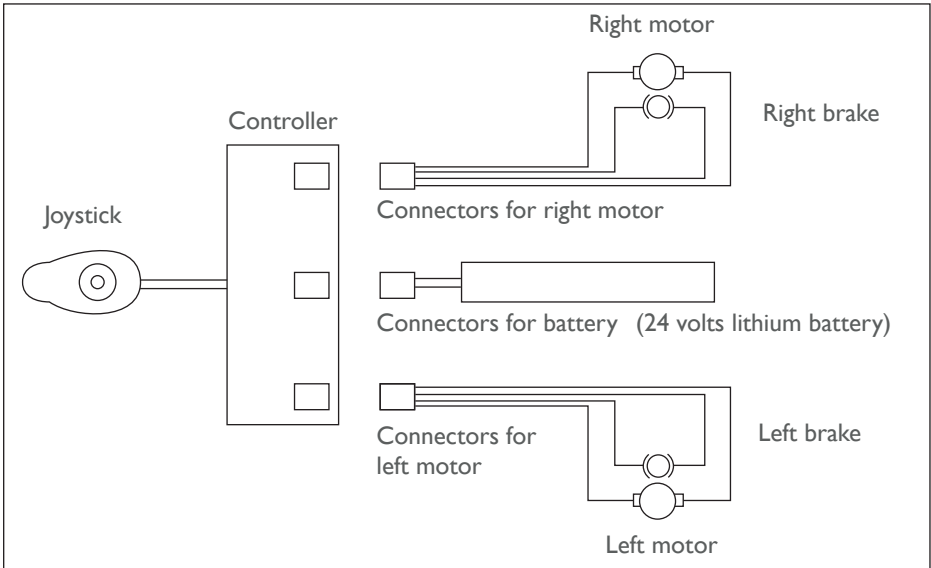

3.3 PRODUCT SOFTWARE VERSION

- Software version of Power Wheelchair N5519 is VI.8.

IV. SPECIFICATION

The main specification includes dimension and weight.

Accessibility	interior
Configuration	2 motorised rear wheels
General dimensions	length: 890 mm
	width : 560 mm
	height : 890 mm
Folded chair dimensions	320 mm x 680 mm x 690 mm
Seat height	460 mm
Seat width	420 mm
Seat depth	400 mm
Armrest height	250 mm
Backrest height	420 mm
Battery weight	1 kg
Wheelchair weight	15.8 kg with battery
Maximum user weight	100 kg
Speed	4,5 km / h
Braking distance	100 cm
Turning radius	90 cm
Turn-around width	100 cm
Static stability	6°
Dynamic stability	3°
Slope capacity	3°
Maximum slope	3°
Obstacle mounting	2,5 cm
Autonomy	10 km
Motors	150W x 2
Lithium batteries	24V 6Ah
Electronic	MICON
Battery charging	by joystick
Front wheels	150 mm
Rear wheels	300 mm
Suspension	front wheels

V. INSTALLATION, FOLDING AND ADJUSTMENT

5.1 INSTALLATION

- Take the wheelchair out of the packing box and put it on the ground. Push the chair-frame apart to the left and right, and press the two tubes on both sides of the seat base down into the grooves on both sides of the chair-frame. (Fig. 2)
- Pull up the handlebars, and lock the folding device.(Fig.3)
- Put the controller on the armrest.And then pull down the tightening spanner on the controller to fasten the controller. (Fig.4)
- Lock the footrests into the frame and then fasten them.(Fig.5)

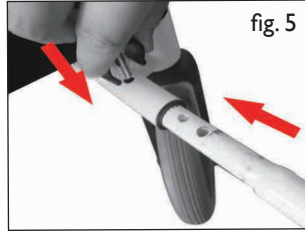
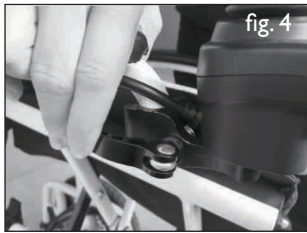

5.2 FOLDING AND STORAGE

Please operate according to below methods of transport and storage of the IZYCHAIR:

- Put the wheelchair on flat ground and turn off the power supply.
- Turn the footrest upward by 90°(Fig.6).
- Press the buttons on both sides of the backrest by your forefingers to release the backrest for packing up the pushing holders.(Fig. 7).
- Pull up the seat cushion (Fig.8), then the chair frame can be folded from both sides; and can also be carried by the two handle straps located at the both sides of the seat. (Fig.9)

5.3 ADJUSTMENT

- When the motor lock lever is pulled downward it is in manual mode, which means that the chair can be pushed manually by an attendant. When the motor lock lever is pulled upward to electric mode, it can't be pushed manually.(Fig. 11)
- Press the joystick power button, the battery indicator light is on.
- Rotate the joystick lever forwards, observe the rotation of the wheelchair wheels, then rotate in the other direction to observe if there is wheel rotation.
- You should observe the wheels come to a stop.
- The armrests can be flipped up, making it easier to get into and out of the chair.(Fig.10)

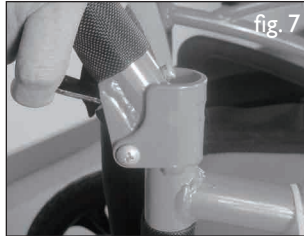

VI. USE AND OPERATION

6.1 USE

6.1.1 Controller:

It is the key component of a wheelchair. All electronics operating the latter are housed in it (fig. 12). The controller is usually installed on one armrest, which is connected to a motor and battery in the power box.

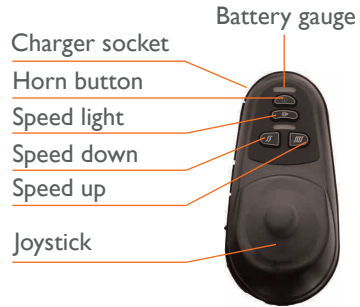

fig. 12

- **Switch button:** The switch button supplies the power to the control system for electronic equipment, then the equipment supplies the power for the wheelchair motor. Do not use the switch button to stop the chair unless in an emergency situation. Otherwise, it may shorten the life of the wheelchair drive components.
- **Joystick:** The joystick is mainly used to control the wheelchair's movement, including its speed and direction (forward, backward and left or right etc). The further you push the joystick from its central position, the faster the wheelchair moves. Whenever you release the joystick, it will automatically return to the center and the brake will be automatically stop the wheelchair.
- **Horn button:** The horn will sound if you press this button.
- **Speed Up/Down Buttons and Speedometer:** After turning on the power, the speedometer shows the current maximum speed setting. This maximum speed setting can be adjusted by the user through the speed up button or speed down button.
- **Charger Socket:** This must only be used by this wheelchair. Do not use the socket to supply power to any other electrical devices equipment. Otherwise, it may damage the wheelchair's control system or its E.M.C performance (Electromagnetic tolerance).



WARNING!

If your wheelchair moves accidentally, immediately release the joystick and the chair will stop automatically.



CAUTION!

If you connect any devices other than the supplied battery charger into the socket, causing damage to the control system, then the warranty is invalid.

6.1.2 Battery Usage

Fully charge your new battery prior to its initial use. This brings the battery up to about 90% of its peak performance level. Give the battery another full charge of 8-14 hours and operate your wheelchair again, the batteries will now perform at over 90% of their potential. After four or five charging cycles, the batteries will top off at 100% charge and last for an extended period. Please replace a new battery when the battery fails, the old battery must be returned to the supplier to avoid unnecessary environmental pollution.



CAUTION!

Do not use your wheelchair when the temperature is less than -25°C or above 50°C.

Battery specification	
Type	Lithium battery
Dimension	162mmx145mmx44 mm
Power	24V
Amperehour	6Ah

6.1.3 Charging batteries

The battery charger is an important part of the wheelchair. The off-board charger attached to this product can charge its batteries quickly and easily to optimize the use of your wheelchair.



CAUTION!

The battery of 24V/2A supplied by our company meets the requirements mentioned in Section I “ General Safety Requirements ” of medical electrical equipment GB9706.1- 2007. The battery must be charged with the charger supplied by us. Any other types of chargers are prohibited.



WARNING!

Never let the battery get cold, do not charge a frozen battery, as this may cause personal injury and battery damage.

Charging the batteries using the off-board charger supplied by us:

- Verify that the controller is powered off and the wheelchair is in drive mode.
- Connect the 3-pin output plug of the charger to the controller. (Fig. 13)
- Connect the power plug of the charger to the standard wall outlet.
- The red LED on the charger lights indicates that the battery is charging. The green LED on the charger lights up when the batteries are fully charged.
- We recommend that you charge the batteries for 8-12 hours.
- Remove the charger and power plug when fully charged, and put them into the bag behind the backrest.

6.1.4 Overcharge

The overcharge protector, which is located in the battery box, is designed for the wheelchair's safety. Once motors or batteries overcharge, the overcharge protector will trip to cut off the power. After one or two minutes, it will automatically reset and then you can continue to drive the wheelchair.

6.1.5 Brake lever

When you want to stop, release the joystick and it will stop immediately.

6.1.6 Safety Belt

For your safety, the safety belt must be fastened before you drive the wheelchair. (fig. 14)

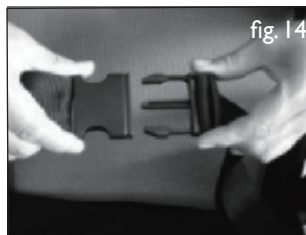
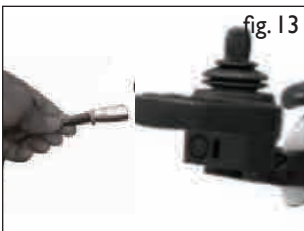

6.2 OPERATION

6.2.1 Preparation before operation

- Do not turn on the power switch when sitting on the IZYCHAIR and turn off the power switch before getting out of the wheelchair.
- Please observe whether the hand brake works or not.
- Please fold the footrest first then hold the armrest to sit on the wheelchair. Do not get out of the wheelchair by stepping on the footrest.
- Otherwise the chair may tip over, which is dangerous.

6.2.2 Practice before operation

- Find a spacious place like a square and have an assistant to help you practice until you have enough confidence to operate it alone.
- Be certain to turn off the power when you get into and out of the wheelchair, and set a speed you feel comfortable with.
- We recommend that you set the lowest speed until you can operate the electric wheelchair competently.
- To practice stopping, push the handle forward and backward, the wheelchair will move anywhere you want.
- Firstly, ensure that it is at the lowest speed when practicing going forward. When competent you can practice “S” shaped turns. After you are familiar with «S» shaped turns, you can practice going backwards, paying attention to the speed control setting. The reverse speed should be lower than the forward speed.

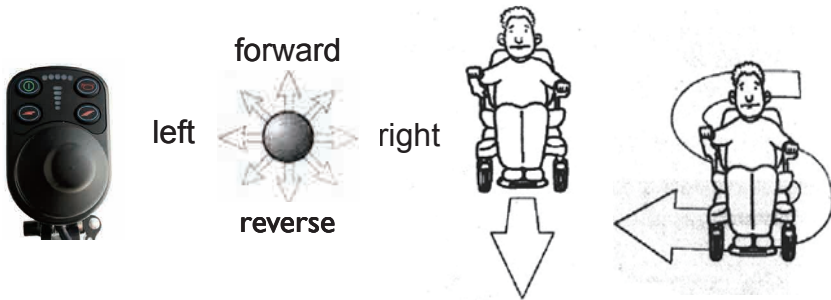

WARNING!

Do not use your wheelchair in manual mode unless with the aid of an assistant. Otherwise this may result in personal injury.



WARNING!

Do not put your wheelchair in manual mode by yourself while you are seated in the wheelchair. Otherwise this may result in personal injury. In this case, please ask your assistant to help you.



WARNING!

Do not put your wheelchair in manual mode when it is on an incline. Otherwise, the wheelchair could lose control and roll downward by itself, and result in personal injury.

VII. FAULT DIAGNOSIS AND TROUBLESHOOTING

This product has an automatic fault warning function for your convenience. Once it malfunctions, the LEDs on the controller will flash with an alarm sounded by the horn. You can find where a fault is using the information in Table 2.

If the problem still exists after checking the fault based on the information in table 2, do not use the wheelchair. Please turn off the power and consult your service agent immediately.

LED display	Fault Diagnosis	Troubleshooting	Remark
1 LED lamp flashes	Battery is at low capacity	charge the battery	
2 LED lamp flashes	Left motor failure	Check the motor and harness wiring	
3 LED lamp flashes	Left brake failure	Check if the brake lever is in the correct position, and if there is damage to the brake	
4 LED lamp flashes	Right motor failure	Check the motor and harness wiring	
5 LED lamp flashes	Right brake failure	Check if the brake lever is in the correct position, and if there is damage to the brake	
6 LED lamp flashes	Overcharge of the controller	Check if the brake is released, and wheels are locked.	
7 LED lamp flashes	Joystick failure	Check if the rocker of the controller is in the central position	
8 LED lamp flashes	Controller failure	Controller fault	
9 LED lamp flashes	Controller failure	Controller fault	

VIII. SAFETY DEVICES AND ACCIDENT MANAGEMENT

- Overcharge protector: Refer to instruction manual 6.1.4
- Safety belt: Refer to instruction manual 6.1.6
- Please release the joystick whenever there is a wheelchair fault, the wheelchair will come to a stop.

IX. MAINTENANCE

Like other motorized vehicles, your power wheelchair also requires routine maintenance. Some checks can be performed by yourself, others you can ask for assistance from your service agent. Preventive maintenance is very important. If you follow the maintenance and checks in this section, your wheelchair will give you years of trouble-free operation. If you have any doubts about your wheelchair's care or operation, please contact your service agent or our after-sales service dept.

9.1 MOISTURE

Your wheelchair, like most electrical and mechanical equipment, is susceptible to external conditions. In any case, the wheelchair should avoid damp environments. Direct or prolonged exposure to water or dampness could cause the wheelchair to malfunction electronically and mechanically. Water can cause electrical components and the chair's frame to corrode.

9.2 TEMPERATURE

- Some parts of your wheelchair are susceptible to changes in temperature.
- In extremely cold temperature, the battery may freeze. Unusual temperatures may cause a lot of components to freeze such as, the charger and battery (such as sealed lead-acid batteries or gel batteries);
- Temperature above 55° may cause a reduction in your wheelchair's speed.

9.3 GENERAL GUIDELINES

- Avoid hitting the controller, especially the joystick.
- Avoid prolonged exposure of your wheelchair to extreme conditions, such as hot, cold or moist environments.
- Keep the controller clean.

- Check all electric connections, including the cable and connectors of the charger, and ensure that they are all tight and secure.
- If only red LEDs are displayed on the battery gauge lights, the batteries are running out of charge. You should recharge the batteries as soon as possible. We recommend charging the battery for 8-12 hours.
- Check the rear wheel inflation, if the tire appears deformed when driving, it should be inflated;
- The frame surface has been sprayed with a clear sealant coating. You can apply a light coat of car wax to keep a high gloss surface.
- Check all cable connections. Ensure that they are fastened and are not corroded. The battery must be placed in the battery area, flat, with the battery plug inward, battery displayed, refer to the correct connection on the main frame label;
- All wheel bearings are lubricated and sealed. There is no need to lubricate them.
- Check if there are loose parts, such as the wheel hub, drive device, and chair itself. If loose, please screw tightly.



WARNING!

Please be sure the tire pressure is within 230KPa±10%. Please inflate the tires with a regulated air source and check with a pressure gauge. Do not exceed the pressure range, otherwise the tires may burst or cause personal injury.

9.4 MAINTENANCE AFTER USE

- Turn off the power.(please disconnect all the connectors if not in use for a long time.)
- Prohibit children and careless people from using the wheelchair.
- Store the wheelchair under normal temperatures to prevent deformation and so that it maintains its performance for a long period.
- Clean and dry the wheelchair with a clear and soft cloth. Never use any chemicals to clean it.(to prevent deformation and discoloration)
- Remove the cloth cover of the seat rest and wash if it is dirty. Dry it before use.

9.5 DAILY CHECKS

In order to keep the wheelchair in good condition, you should check it before each use. In order to maintain the weekly, monthly, and biannual checks, see Table III.

Items for inspection	At any time	Weekly	Monthly	Biannually
All parts			•	
Joystick function	•			
Brake System	•			
Connection		•		
Battery Condition	•			
Tire Condition			•	
Frame Condition				•
Front Wheel Condition		•		
Cleanliness	•			

9.6 CLEANING

Cleaning instructions:

- Never wash your wheelchair with water or expose it directly to water.
- The surface of the wheelchair frame is sealed with a protective coating.

Therefore, it is very easy to wipe it clean with a damp cloth. Never use any chemicals to clean the vinylon seat and armrest, as they may become slippery or cracked. You can use a damp cloth and neutral soapy water to clean them, and then dry them thoroughly.

X. REPAIR

- Users may need to repair or replace some spare parts like the push handle and push handle cover which can be repaired or replaced by users under the instructions of after-sales service staff or our dealers.
- Under the warranty, our company or dealers will repair or replace the faulty spare parts, such as the motor, battery, charger, controller, bearings, etc., due to material or manufacturing defects, free of charge.
- The spare parts such as the motor, controller, etc. which are validated by the after sale staff or our dealers, can be sent to our company for maintenance.
- Please contact your distributor or the after-sale service dept. of our company for any questions regarding the maintenance of power wheelchairs. Please refer to XIII. Product Warranty.



CAUTION!

In order to guarantee the quality of the power wheelchair, please contact us or our dealers to replace the spare parts with the same models and specifications if the parts like the batteries, tyres, controller, motors and charger, etc. need to be replaced. The maintenance should be carried out at our company or the dealers' maintenance dept.

XI. STORAGE

Your wheelchair should be stored in dry conditions free from sources of extreme temperature and dampness. Remove the batteries from the wheelchair prior to storage. Otherwise, the frame may rust and the electronics may be damaged.

XII. OPENING AND VERIFICATION

Open the packing box and check whether there is anything damaged or missing.

Packing List:

No.	Name	Quantity	Remark
1	Electric Wheelchair	1pc	Model:N5519
2	Charger	1pc	Model:HP0060WL2/60 HZ 24V2A
3	Instruction Manual	1pc	
4	Footrest	2pc	
5	Controller	1set	

XIII. WARRANTY

13.1 FIVE-YEAR WARRANTY

Our company has passed the ISO9001 and ISO13485 certificate. The quality is guaranteed.

13.2 COVERED BY WARRANTY:

Five years warranty on the front and the rear main frames from the date of purchase.

One-year warranty on the following parts from the date of purchase:

- Electric Control system and the controller
- Motor/gearbox assembly
- Charger
- Lithium battery

Warranty service will be performed by your provider in cooperation with our after-service department.

13.3 NOT COVERED BY WARRANTY:

- ABS Shroud and rubber pads.
- Tires
- Seating and upholstery
- Damage caused due to abuse, misoperation, accident and negligence
- Damage caused due to improper operation, maintenance and storage
- Business or other abnormal use

IzyCHAIR

by

LOGO  SILVER
by **AMYLOR**

Logo Silver

32 rue de Comboire - 38130 Echirolles - France
Tél. +33(0)4 76 21 22 19 - contact@logo-silver.fr

www.logo-silver.fr